



21006540

MAGTECH INDUSTRIES

Buy Now



Looking for a discount?

[Check out our current promotions!](#)

Give us a call

1-855-837-4225

International: 1-415-281-3866

Email Us

Sales and New Orders: sales@verical.com

Order Support: support@verical.com

Suppliers: [Visit our seller page](#)

Company Address

Arrow Electronics, Inc
9201 East Dry Creek Road
Centennial, CO 80112

MAGNETIC CARD READER DESIGN KIT TECHNICAL SPECIFICATION

Part Number: 99821002 Rev 21

FEBRUARY 2011

MAGTEK[®]

REGISTERED TO ISO 9001:2008

1710 Apollo Court

Seal Beach, CA 90740

Phone: (562) 546-6400

FAX: (562) 546-6301

Technical Support: (651) 415-6800

www.magtek.com

Information in this document is subject to change without notice. No part of this document may be reproduced or transmitted in any form or by any means, electronic or mechanical, for any purpose, without the express written permission of MagTek, Inc.

MagTek is a registered trademark of MagTek, Inc.

REVISIONS

Rev Number	Date	Notes
1	4/7/97	Initial Release
2	6/10/97	Added Tech Support Phone Number on Title Page
3	4/1/98	Added BOM For Doc
4	5/1/98	Fixed Date
5	5/7/98	Revised #4 Washer, para 3.1
6	3/10/99	Incorporated all documents and drawings into basic document and formatted for PDF files
7	11/30/99	Changed 99821066 to reflect PCB layout. Changed 99875063 UART to USART. Dwg 21062320 and Dwg 21062321 added substitute terminal.
8	01/19/00	Section 3.1 and Appendix 1: For Insertion Readers, deleted drawing numbers 21062320 and 21062321 and replaced with 21062342, 21062343, 21062344, 21062334, 21062336; Deleted drawing numbers 21053904 and 21053907 and replaced with 21053909, 21053910, and 21053911. Added drawings 16037701, 48190004 and Spec 85800004.
9	10/2/00	Updated and added document 99875065-3. Updated and added document 99821066-9
10	01/08/01	Updated Dwg 21062336 from Rev 2 to Rev A
11	02/20/01	Reformatted pagination
12	06/06/02	Updated with revised 99821066 drawing
13	08/06/02	To Design Requirements, added 5 Molex mating connectors
14	04/08/03	Front Matter: added ISO line to logo
15	04/23/03	Sec 2: parts required, changed drawing 21052051 to 21052071. In Drawings, replaced Drawing 21052051 with 21052071, 99821066-10 with -11, 99875063-3 with -4, 99875064-2 with -3, 99875065-3 with -4
16	07/01/03	Section 1: Editorial throughout to match drawing changes. Drawing Section: added drawings: 21052169, 21052170, 21052176, 21052177, 21062358, 21062360, 68110110, 68110111; deleted drawings: 21052168, 21052178, 21052179, 21052183, 21053909, 21062334, 21062336, 21062342, 21062343, 21062344.
17	10/31/05	Updated to include 5mm (ULP) head family and Delta ASIC
18	2/17/06	Replaced head and pivot pins with shorter versions
19	5/19/06	Added 2-track beam head (21062300 & 21062309)
20	3/12/08	Added 21052207 on Accordion Spring; added Encrypting IntelliHeads to related documents
21.01	2/14/11	Removed 2-track head assemblies for insert readers; added 21030075

Table of Contents

1. SCOPE	1
1.1. PURPOSE	1
1.2. READ HEADS	1
1.3. ELECTRONIC DESIGN	1
2. DESIGN REQUIREMENTS FOR SWIPE READERS	1
2.1. PARTS REQUIRED	1
2.2. READER BODY DESIGN	1
2.3. HEAD POSITION AND LOCATION	2
2.3.1. Horizontal Position	2
2.3.2. Vertical Position.....	2
2.3.3. Perpendicularity of Head to Card	2
2.4. CARD SLOT DESIGN	2
2.4.1. Width	2
2.4.2. Height	2
2.4.3. Length.....	2
2.5. SPRING CONTROL	3
2.6. MATERIALS	3
2.6.1. Reader Body	3
2.6.2. Wear Strip.....	3
3. DESIGN REQUIREMENTS FOR INSERT READERS	3
3.1. PARTS REQUIRED	3
3.2. READER BODY DESIGN	3
3.3. HEAD POSITION AND LOCATION	3
3.3.1. Horizontal Position	3
3.3.2. Vertical Position.....	4
3.4. CARD PATH.....	4
3.4.1. Width	4
3.4.2. Height	4
3.4.3. Length.....	4
3.5. SPRING CONTROL	4
3.6. MATERIALS	4

Tables and Figures

Figure A-1.	Head Pin (Used for Beam Style Head Mounting)	6
Figure A-2.	Pin – Pivot (Used for Beam Style Head Mounting).....	7
Figure A-3.	Head Spring (Used for Beam Style Head Mounting).....	8
Figure A-4.	Head Spring (Used for Beam Style Head Mounting).....	9
Figure A-5.	3-Track Read Head on Butterfly Spring	10
Figure A-6.	2-Track Read Head Assembly with Cable and 7-Pin Connector.....	11
Figure A-7.	3-Track Read Head Assembly with Cable and 7-Pin Connector.....	12
Figure A-8.	3 Track Read Head 5mm Accordion Spring	13
Figure A-9.	Pivot Plate	14
Figure A-10.	Swipe Reader Design Criteria	15
Figure A-11.	Insert Reader Design Criteria	16
Figure A-12.	Swipe Reader Design Criteria for Accordion Spring.....	17
Figure A-13.	3-Track Read Head on Low Profile Beam Arm	18
Figure A-14.	3-Track Read Head on Beam Assembly with Cable and 7-Pin Connector	19
Figure A-15.	Washer-Flat SS 0.101 ID x 0.183 OD x 0.020 Thick	20
Figure A-16.	Magnetic Head, 2-Track Read, Ultra Low Profile	21
Figure A-17.	Magnetic Head, 3-Track Read, Ultra Low Profile	22
Figure A-18.	ASCII Character Conversion Chart.....	23

1. SCOPE

1.1. PURPOSE

The purpose of this document is to provide general information relating to the mechanical design of both swipe and insert Magnetic Stripe Readers.

1.2. READ HEADS

The suggestions and guidelines contained in this document can be used to design magnetic stripe readers using conventional heads which are listed in the **Parts Required** tables below. Alternatively, the MagTek IntelliHead family of products can be used in these same readers. Information about the IntelliHead products can be found in some of the documents listed in the table in Appendix A.

1.3. ELECTRONIC DESIGN

This kit does not address the design of the electronics or the firmware required to extract information from the magnetic stripes. However, MagTek offers a triple-track ASIC (Delta ASIC, p/n 21006540/21006541) which can be used to simplify the reading of the magnetic data. Refer to the table in Appendix A to locate the related documentation.

2. DESIGN REQUIREMENTS FOR SWIPE READERS

2.1. PARTS REQUIRED

Butterfly Spring Assembly

Qty	Description	MagTek Part Number
1	Swipe Reader Design Criteria	21053902
1	2-track Head Assembly (TK 1, 2 or 2, 3); 7-pin connector*	21052198
	3-track Head Assembly; 7-pin connector*	21052199
2	Pivot Plates	21053503
2	#4 x 0.25 long Self Tapping Screw Type B	N/A

Accordion Spring Assembly

Qty	Description	MagTek Part Number
1	Swipe Reader Design Criteria	21053914
1	3 Track Head Assembly; 7-pin connector*	21052207

* Mates with any Molex series: 53398, straight, SMT; 53261, Right Angle, SMT; 53047, Straight, Thru Hole; 53048, Right Angle, Thru Hole; and 51047, to Wires.

2.2. READER BODY DESIGN

The critical areas and dimensions of the swipe reader body are shown in drawing 21053902 (for butterfly spring designs) and 21053914 (for accordion spring designs); both are located in Appendix A.

2.3. HEAD POSITION AND LOCATION

The Head Assembly consists of a thin, flexible head mount spring that doubles as a locator and supplies the force for the head-to-card contact.

2.3.1. Horizontal Position

The gap is located longitudinally, midway between the pivot pins of the pivot plates, centered in the opening of the reader body.

2.3.2. Vertical Position

The centerline of the gap (width) is mounted on the line connecting the centers of the pivot plate mounting holes, Datum B in drawing 21053902. Datum B is also the centerline of Track 2 which is located 0.408 inch (10.4mm) from the top edge of the Magnetic Card, Datum C. Reference Datum B and Reference Datum C must be parallel within 0.003 inch (0.076mm) in order to minimize the rotational displacement between the read head and the recorded bit on the card.

2.3.3. Perpendicularity of Head to Card

The force exerted on the card is dependent on the assembly of the head into the spring, the spring rate, and the subsequent location of the head/card contact point (crown) to the mounting surface of pivot plates. The controlling dimension is 0.278 inches (7.061mm) with a tolerance of 0.003 inch (0.076mm). The head rests against the far wall with the flexed spring exerting a very light force. The insertion of the card raises the force to the level required for reliable head performance.

2.4. CARD SLOT DESIGN

2.4.1. Width

The card slot is configured to operate with card thickness of 0.010 to 0.033 inch (0.254 to 0.838mm). The slot width is 0.034 to 0.038 inches (0.864 to 0.965mm). Draft angles used in the making of this part (injected molding) must be within the 0.004 inch (0.102mm) allowance. The slot width of 0.038 to 0.042 inch (0.965 to 1.067mm) must be maintained to minimize the tilt of the card in the slot. The card travels through the slot at the whim of the operator with a great deal of tilting within the slot axis. The read head must follow the tilts in order to work correctly. Excessive slot width will allow the card to lean to the limit of the compliance in the head spring system as well as displacing the track vertically.

2.4.2. Height

The height of the slot should be no less than 0.75 inch (19.05mm) and no more than 1.25 inches (31.75mm). The low limit is to prevent excessive tilt of the card in the slot and the upper limit prevents the embossing on the card from entering the slot.

2.4.3. Length

The minimum length should not be less than 1.75 inches (44.45mm) from the centerline of the head to either end. Two inches (50.8mm) is the minimum

distance required to insure the edge of the card is fully in contact with reference Datum C. Shorter distances will allow the card to assume a nose up slant and enter the read head too high, or nose down prematurely on leaving, resulting in misreads. The longer the slot, the better.

2.5. SPRING CONTROL

The pivot pins enter 0.090 inch (2.286mm) diameter holes that have a raised hub of 0.150 inch (3.81mm) diameter and a dimension from the far wall of 0.118 inch (2.997mm). Operators have a tendency, at times, to test their ability to traverse the card through the slot at a high rate of speed. The resulting card to head impact slides the head sideways off the pivot pin. The hole and hub arrangement prevents the disengagement. Neither head nor spring suffers from impact, but the system is disabled by a displaced head.

2.6. MATERIALS

2.6.1. Reader Body

Recommended materials for the reader body are ABS or Polycarbonate (PC) + 15% Glass (or other suitable material). Both should have the UL 94 V0 rating.

2.6.2. Wear Strip

Wear strips are optional depending on application requirements.

3. DESIGN REQUIREMENTS FOR INSERT READERS

3.1. PARTS REQUIRED

Qty	Description	MagTek Part Number
1	3-track Low Profile Head Assembly; 7-pin connector*	21062368
1	Pin – Head (Low Profile)	16035003
1	Pin – Pivot (Low Profile)	16035004
1	Head Spring	16037701
1	Retaining Ring (E Type 3/32 Shaft, e.g. Waldes Truarc 5133-9)	85800004
1	Flat Washer	48190004

* Mates with any Molex series: 53398, straight, SMT; 53261, Right Angle, SMT; 53047, Straight, Thru Hole; 53048, Right Angle, Thru Hole; and 51047, to Wires.

3.2. READER BODY DESIGN

The critical areas and dimensions of the insert reader body are shown in drawing 21053906 located in Appendix A.

3.3. HEAD POSITION AND LOCATION

The Head Assembly consists of a ridged beam head mount. A spring supplies the force for the head-to-card contact.

3.3.1. Horizontal Position

See drawing 21053906 in Appendix A for position.

3.3.2. Vertical Position

The centerline of the gap (width) is mounted on the line connecting the centers of the pins (head and pivot) mounting holes, Datum A in drawing 21053906. Reference Datum A and Reference Datum C must be parallel within 0.003 inch (0.076mm) in order to minimize the rotational displacement between the read head and the recorded bit on the card.

3.4. CARD PATH

3.4.1. Width

The width of the Card Path should be 2.134 inches $+0.004 / -0.000$ (54.20mm $+0.102 / -0.000$).

3.4.2. Height

The Card Path is configured to operate with card thickness of 0.010 to 0.033 inch (0.254 to 0.838mm). The Card Path height is 0.038 to 0.042 inch (0.965 to 1.067mm).

3.4.3. Length

The length of the Card Path should accommodate card reading requirements. In order to read a full ISO-encoded track, the slot must accommodate the full length of the card with the edge of the card just past the crown of the head when the card is fully inserted.

3.5. SPRING CONTROL

The recommended force of the spring is 5 to 8 ounces (142 to 227 grams) with the card inserted.

3.6. MATERIALS

Recommended materials for the reader body are ABS or Polycarbonate (PC) + 15% Glass (or other suitable material). Both should have the UL 94 V0 rating.

Appendix A. Documents and Drawings List

Table A-1. List of Drawings

Part Number	Description	Page #
16035003	Figure A-1. Head Pin (Used for Low Profile Beam Style Head Mounting)	6
16035004	Figure A-2. Pivot Pin (Used for Low Profile Beam Style Head Mounting)	7
16037701	Figure A-3. Head Spring (Used for Beam Style Head Mounting)	8
21052194	Figure A-4. 2-Track Read Head on Butterfly Spring	9
21052195	Figure A-5. 3-Track Read Head on Butterfly Spring	10
21052198	Figure A-6. 2-Track Read Head Assembly with Cable and 7-Pin Connector	11
21052199	Figure A-7. 3-Track Read Head Assembly with Cable and 7-Pin Connector	12
21052207	Figure A-8. 3 Track Read Head 5mm Accordion Spring	13
21053503	Figure A-9. Pivot Plate	14
21053902	Figure A-10. Swipe Reader Design Criteria	15
21053906	Figure A-11. Insert Reader Design Criteria	16
21053914	Figure A-12. Accordion Spring Swipe Reader Design Criteria	17
21062366	Figure A-13. 3-Track Read Head on Low Profile Beam Arm	18
21062368	Figure A-14. 3-Track Read Head on Beam Assembly with Cable and 7-Pin Connector	19
48190004	Figure A-15. Washer-Flat SS 0.101 ID x 0.183 OD x 0.020 Thick	20
68100115	Figure A-16. Magnetic Head, 2-Track Read, ULP	21
68100116	Figure A-17. Magnetic Head, 3-Track Read, Low Profile	22
85800004	Retaining Ring, E Type, 3/32 Shaft	n/a
99875065	Figure A-18. Application Note: Character Conversion	23

Table A-2. Related Documents

Part Number	Description	Use Figure on page	Related Document
21006540	3-volt Triple Track Decoder with Shift-Out Interface (tube)	n/a	99875337
21006541	3-volt Triple Track Decoder with Shift-Out Interface (tape & reel)	n/a	99875337
21030001	3-Track Shift-Out IntelliHead on Butterfly Spring	12	99875258
21030002	2-Track Shift-Out IntelliHead on Butterfly Spring	11	99875258
21030005	3-Track RS-232 IntelliHead on Butterfly Spring	12	99875293
21030006	3-Track USB HID IntelliHead on Butterfly Spring	12	99875320
21030007	3-Track USB KB IntelliHead on Butterfly Spring	12	99875321
21030013	3-Track Shift-Out IntelliHead on Accordion Spring	13	99875258
21030015	3-Track USB HID IntelliHead on Accordion Spring	13	99875320
21030016	3-Track USB KB IntelliHead on Accordion Spring	13	99875321
21030017	3-Track RS-232 IntelliHead on Accordion Spring	13	99875293
21030018	3-Track Shift-Out IntelliHead on Beam Arm	19	99875258
21030033	3-Track Encrypting SPI IntelliHead on Butterfly Spring	12	99875352
21030035	3-Track Encrypting SPI IntelliHead on Beam Arm; 125mm/8P	19	99875352
21030038	3-Track Encrypting SPI IntelliHead on Accordion Spring	13	99875352
21030075	3-Track Encrypting SPI IntelliHead on Beam Arm; 50mm/10P	19	99875352

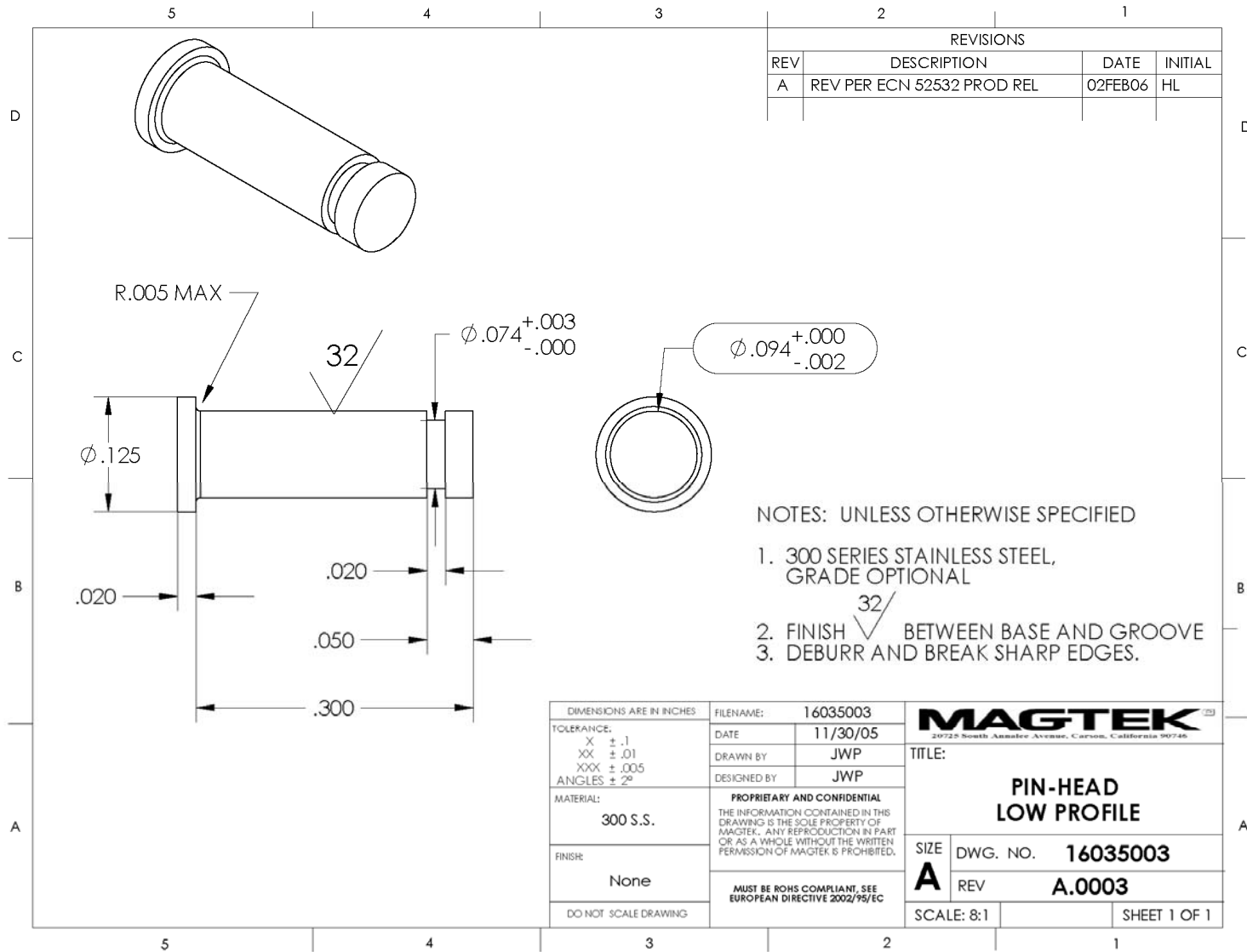

Figure A-1. Head Pin (Used for Beam Style Head Mounting)

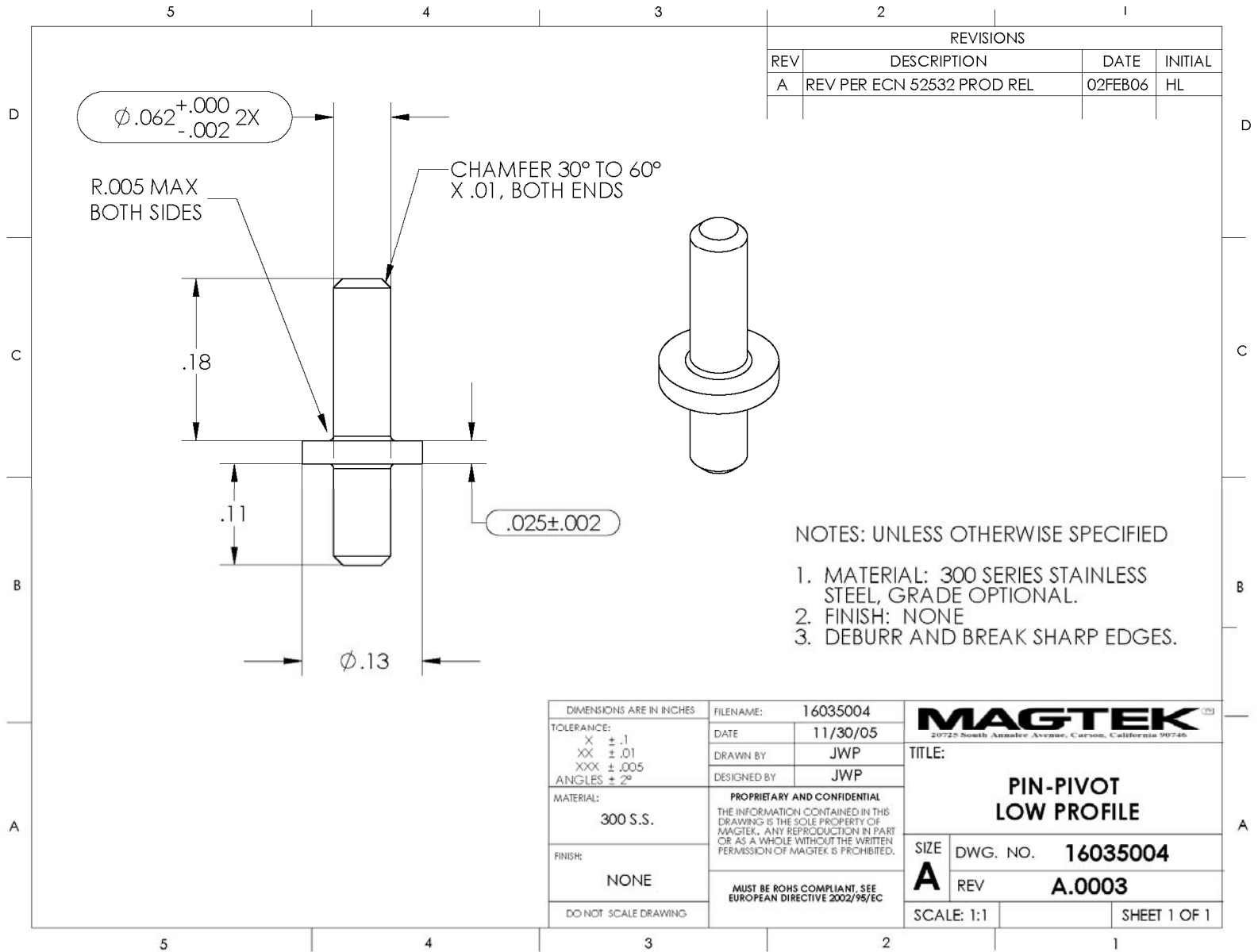

Figure A-2. Pin – Pivot (Used for Beam Style Head Mounting)

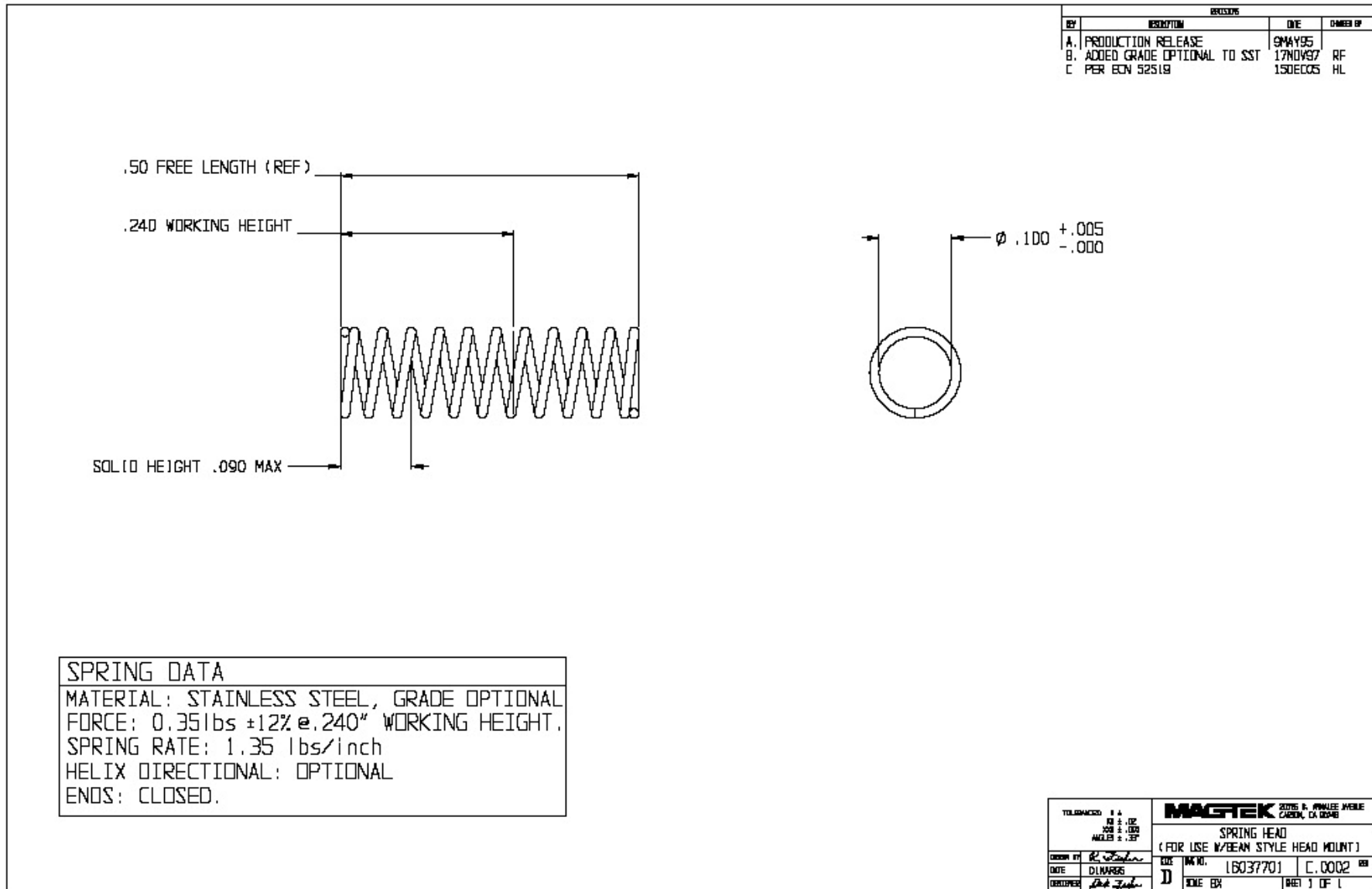

Figure A-3. Head Spring (Used for Beam Style Head Mounting)

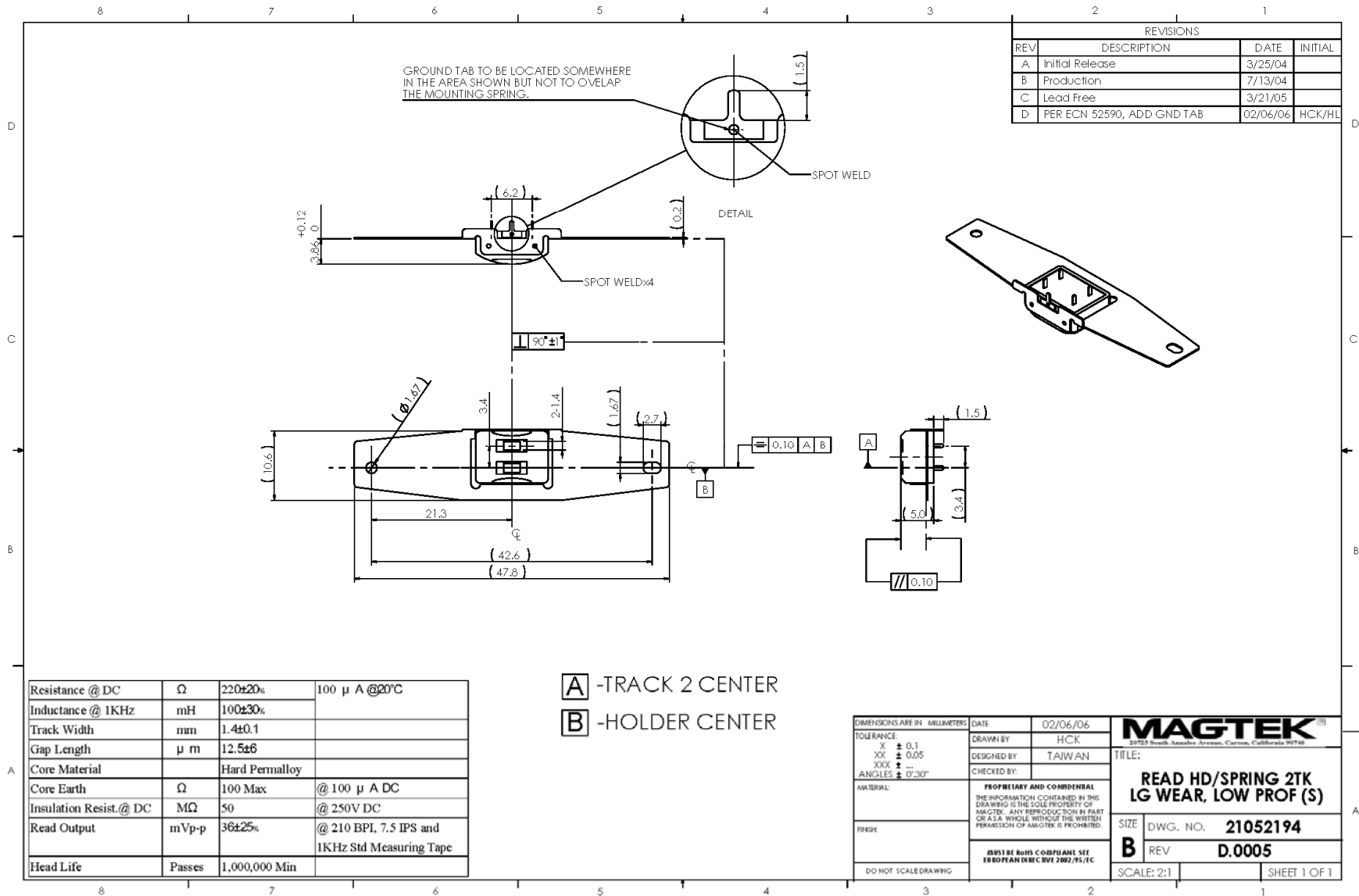

Figure A-4. Head Spring (Used for Beam Style Head Mounting)

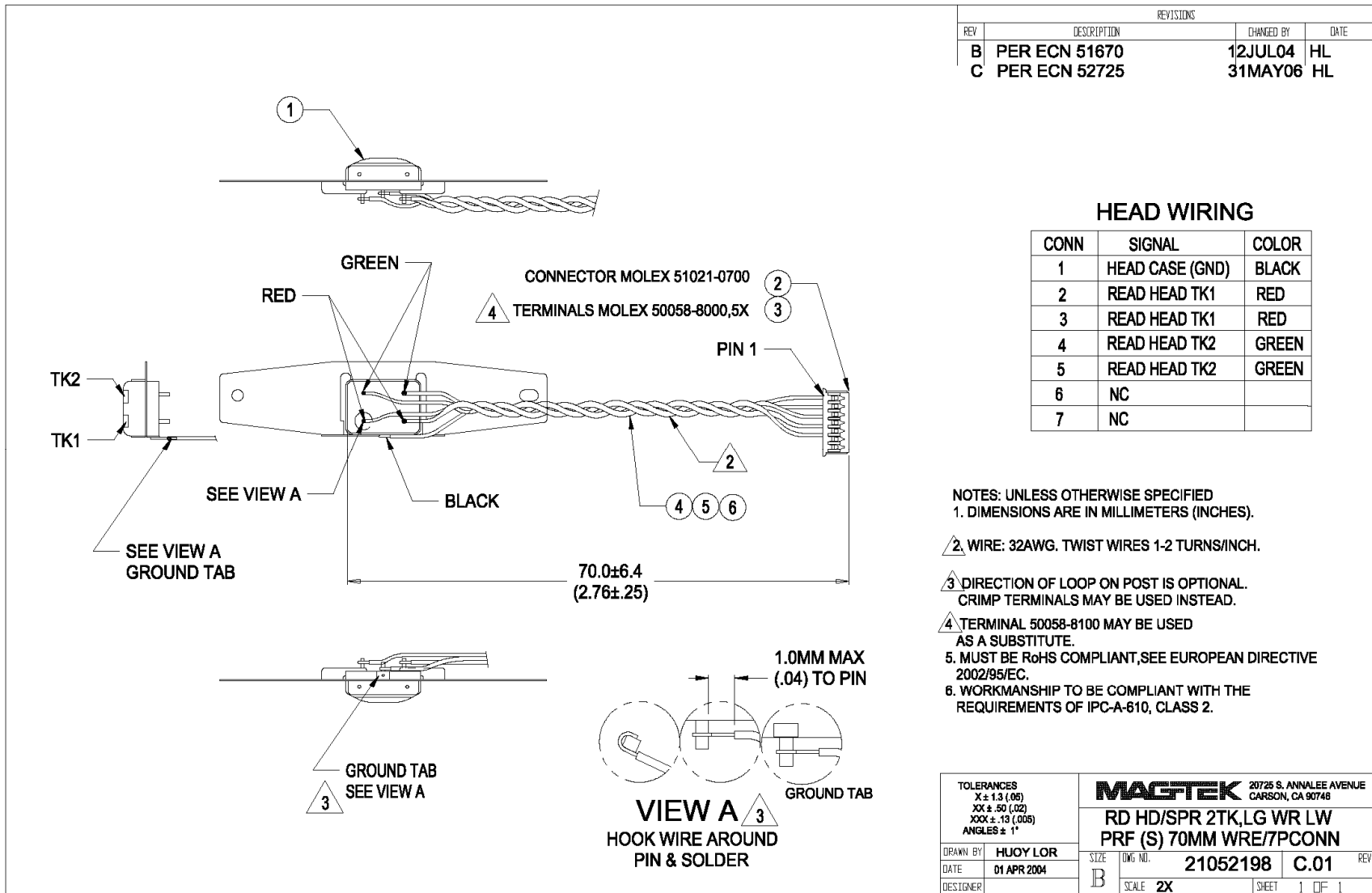

Figure A-6. 2-Track Read Head Assembly with Cable and 7-Pin Connector

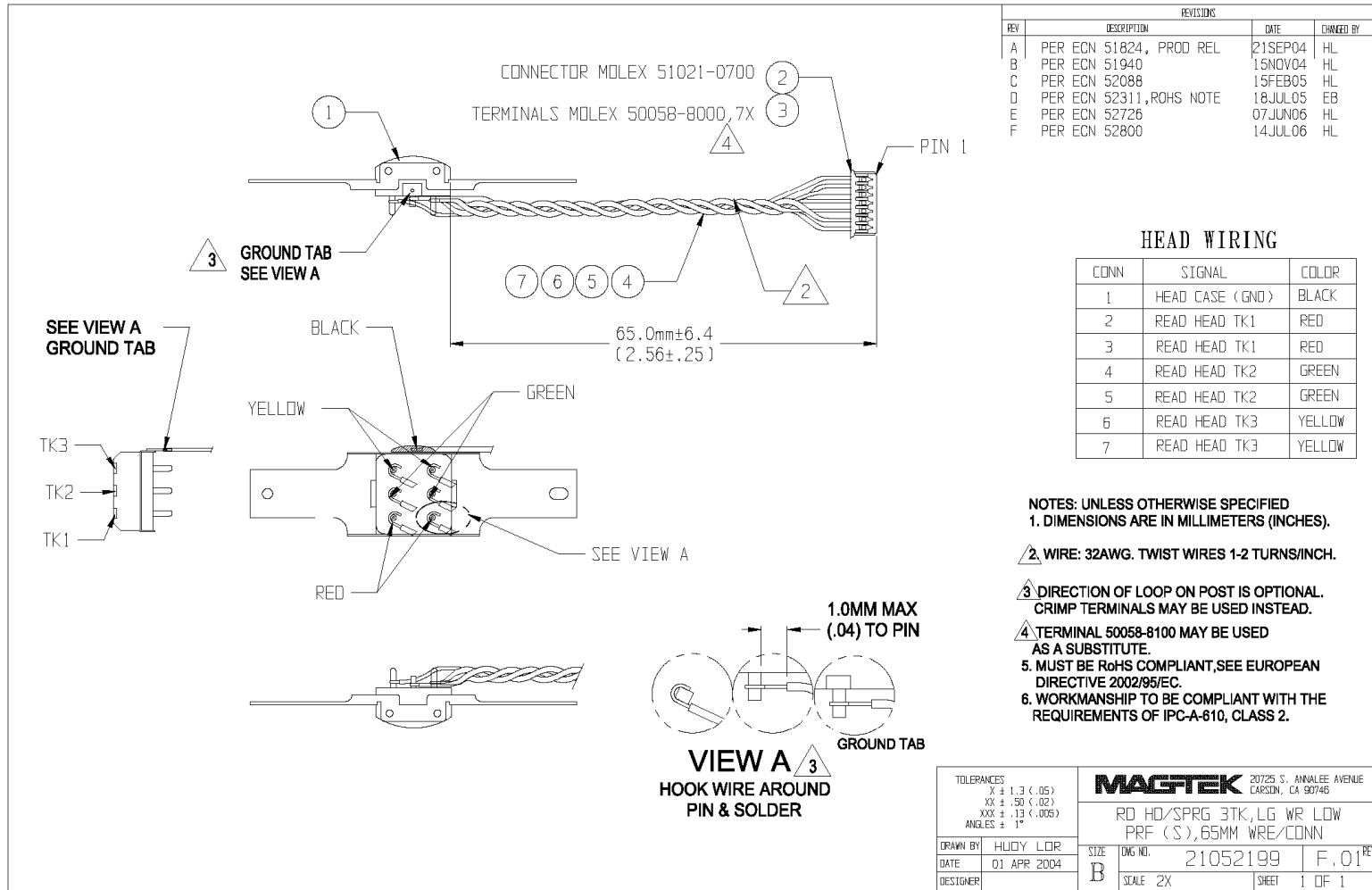

Figure A-7. 3-Track Read Head Assembly with Cable and 7-Pin Connector

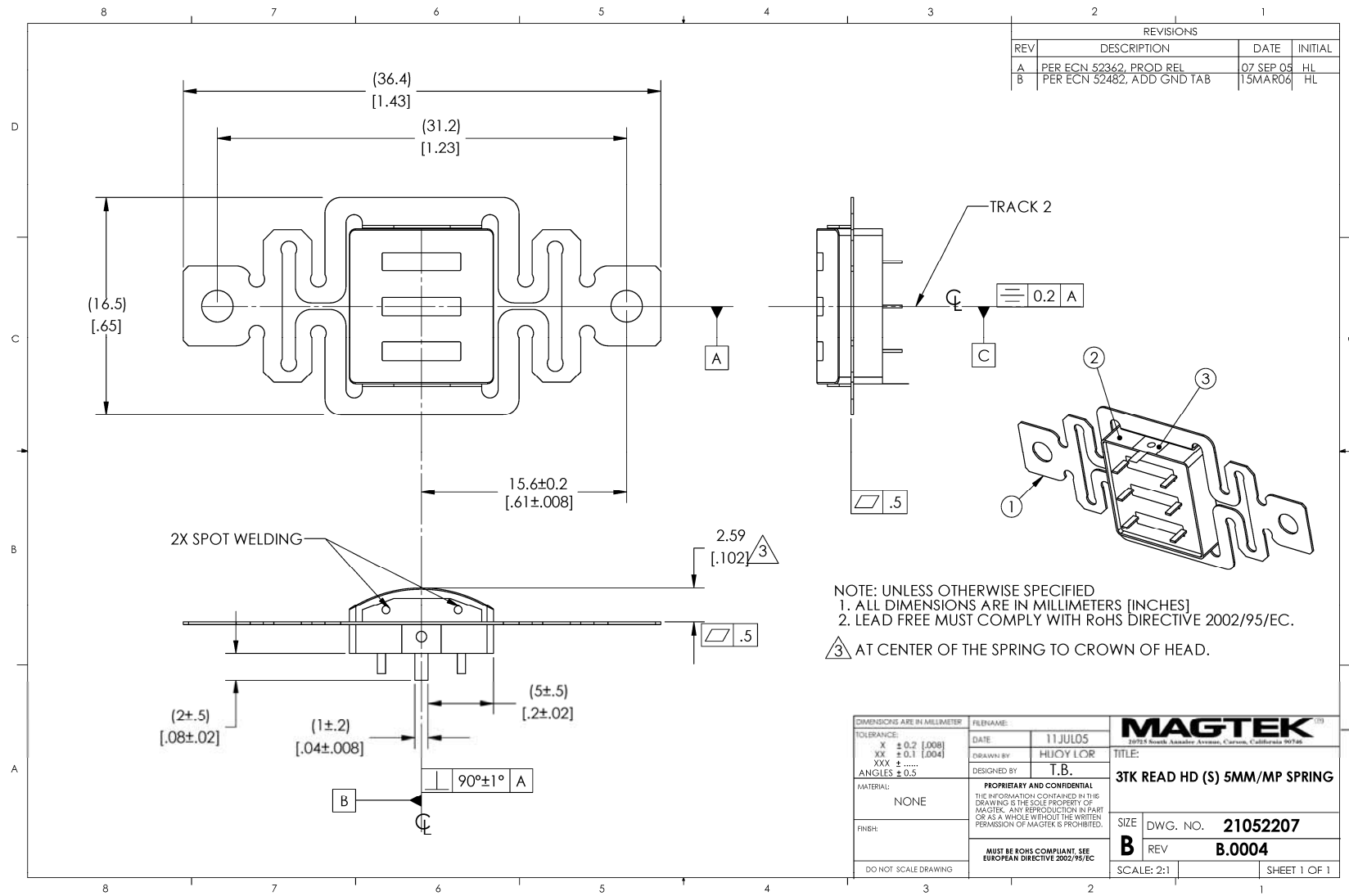

Figure A-8. 3 Track Read Head 5mm Accordion Spring

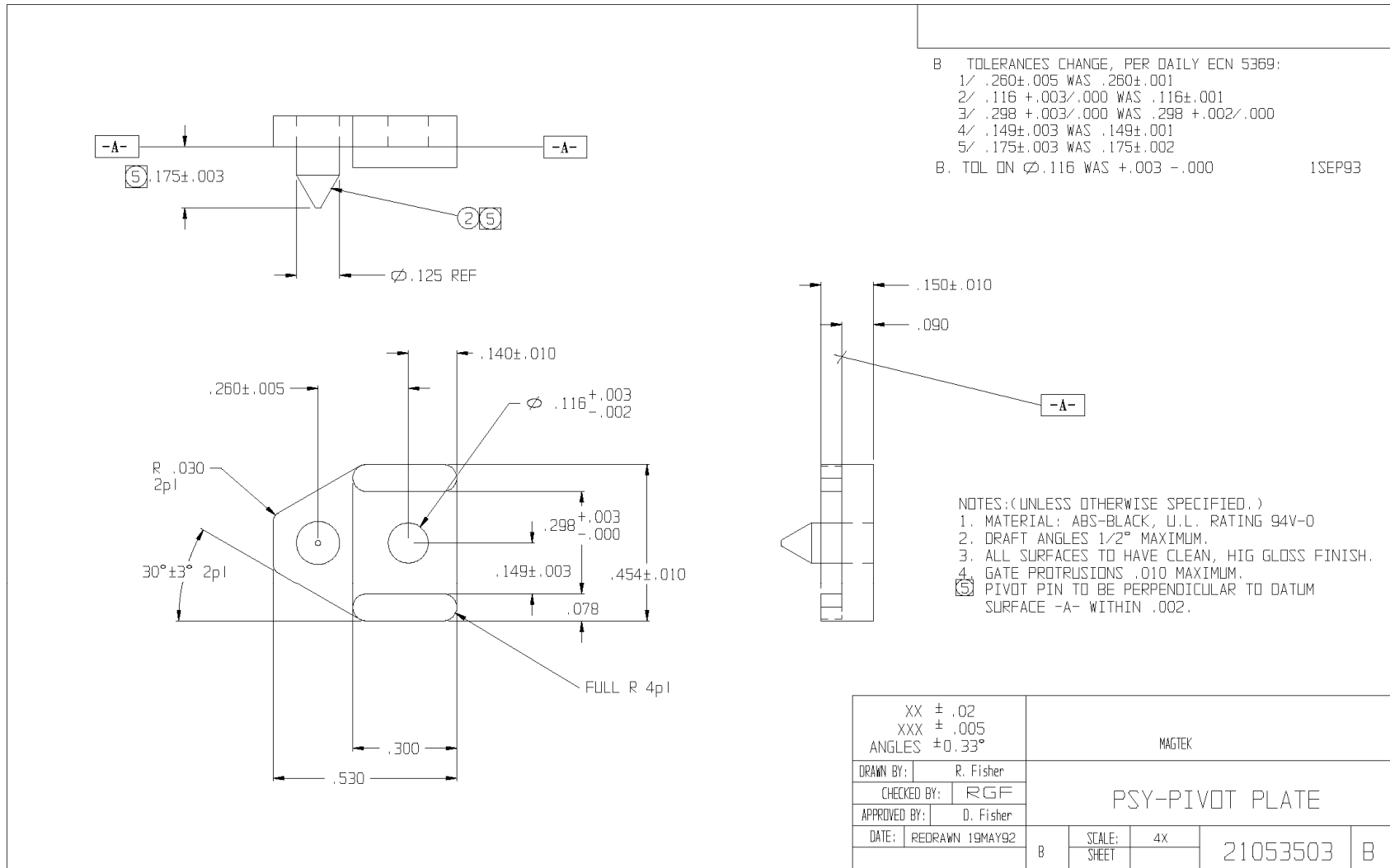

Figure A-9. Pivot Plate

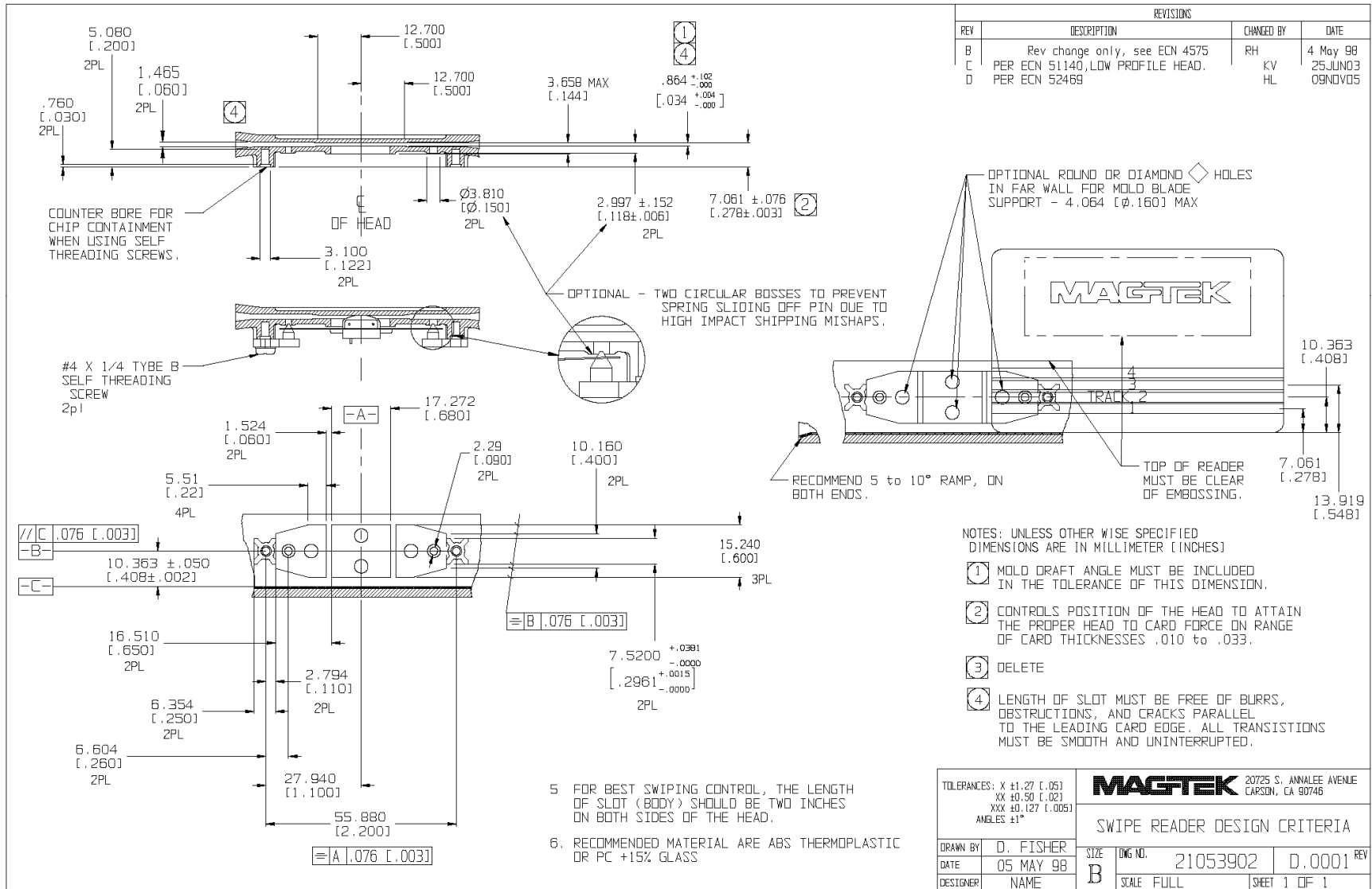

Figure A-10. Swipe Reader Design Criteria

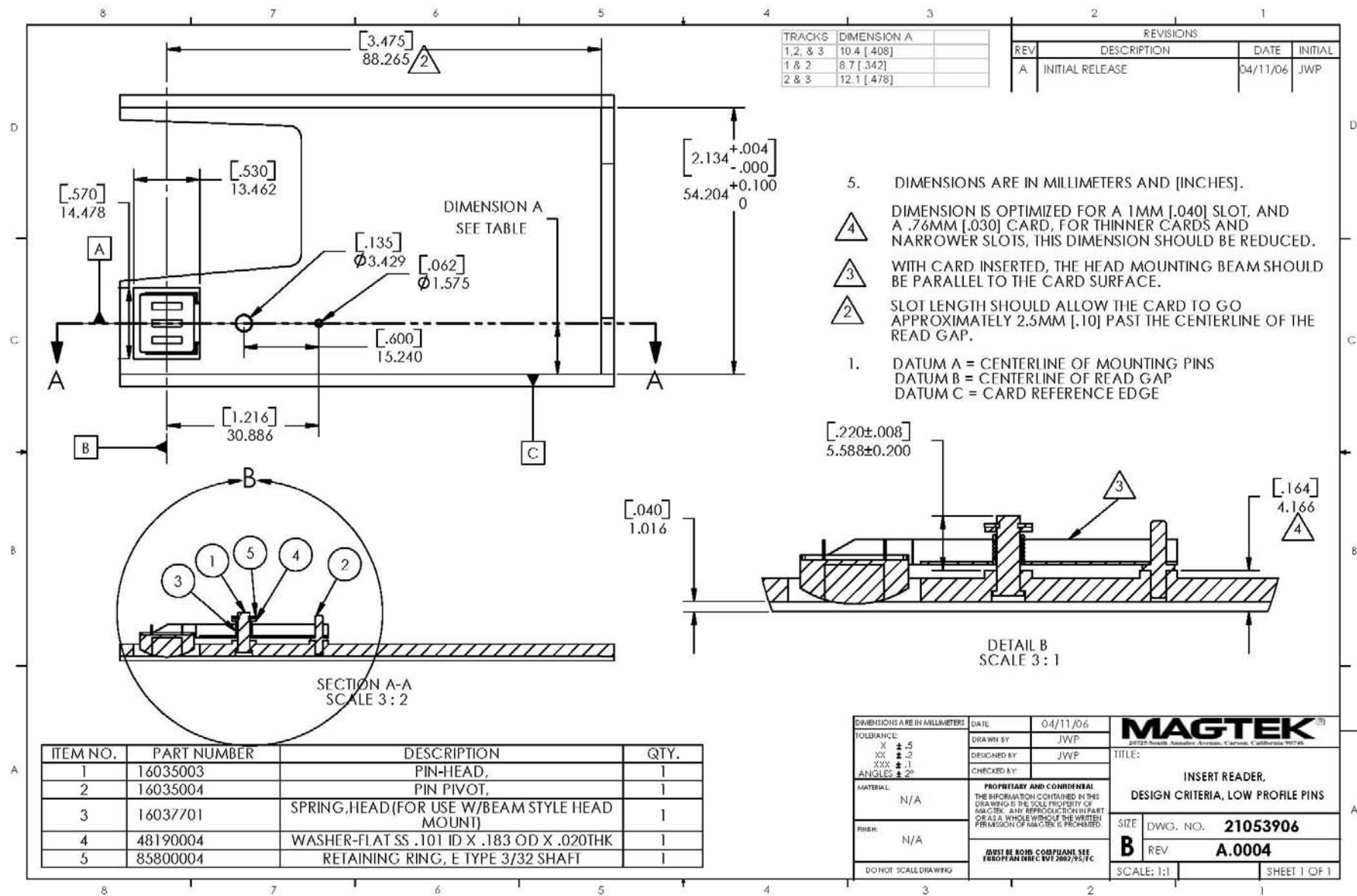

Figure A-11. Insert Reader Design Criteria

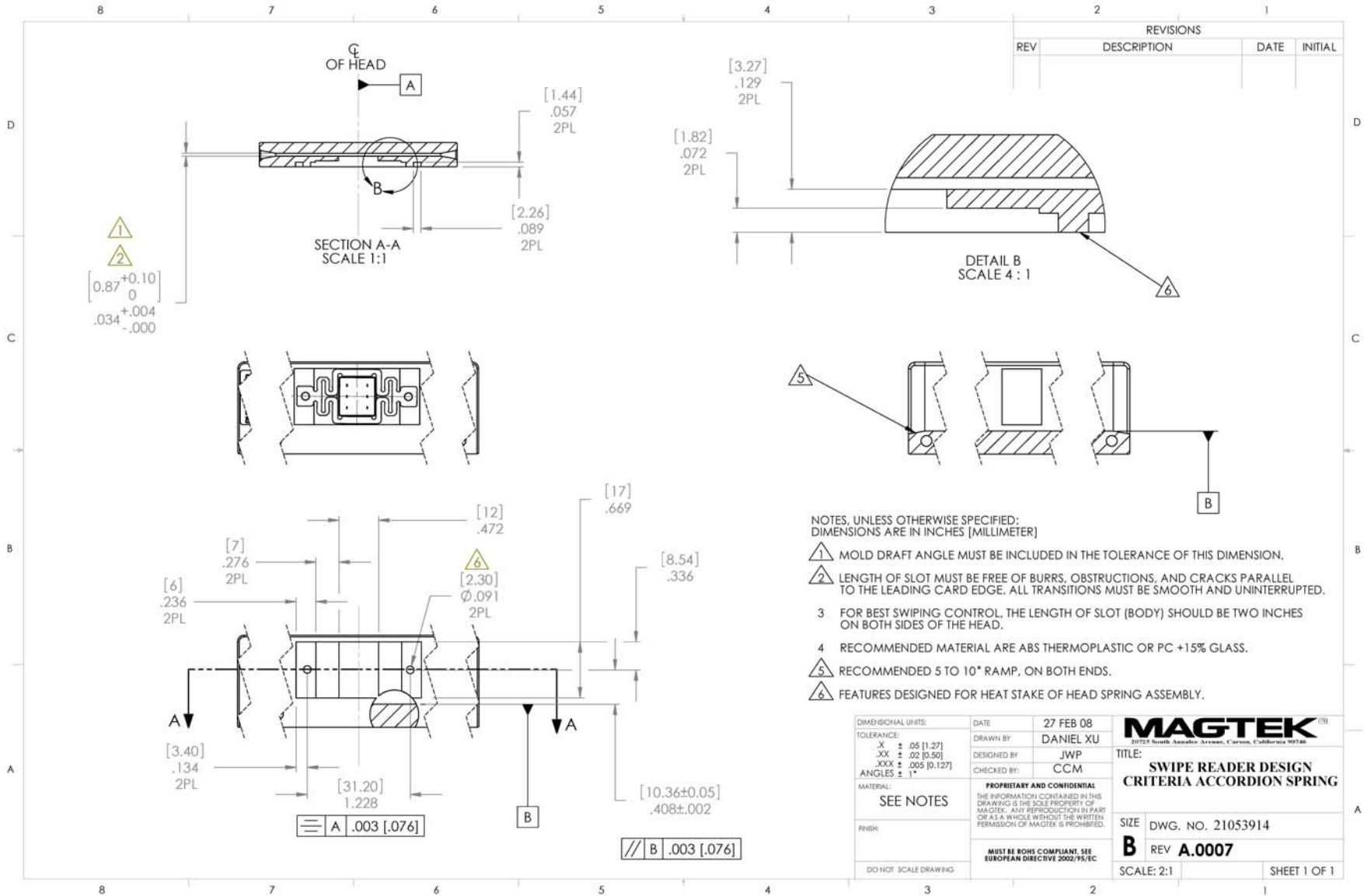

Figure A-12. Swipe Reader Design Criteria for Accordion Spring

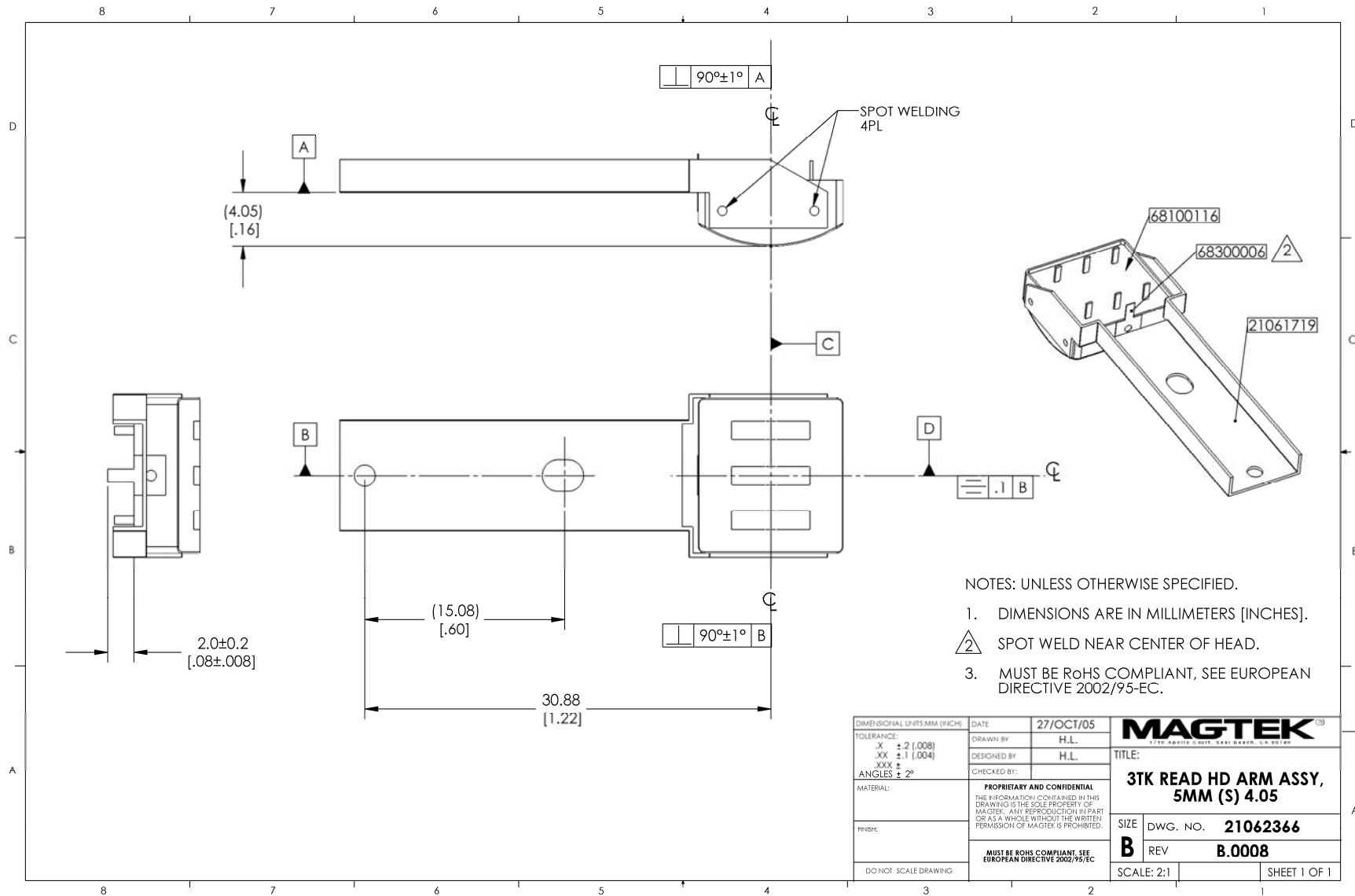

Figure A-13. 3-Track Read Head on Low Profile Beam Arm

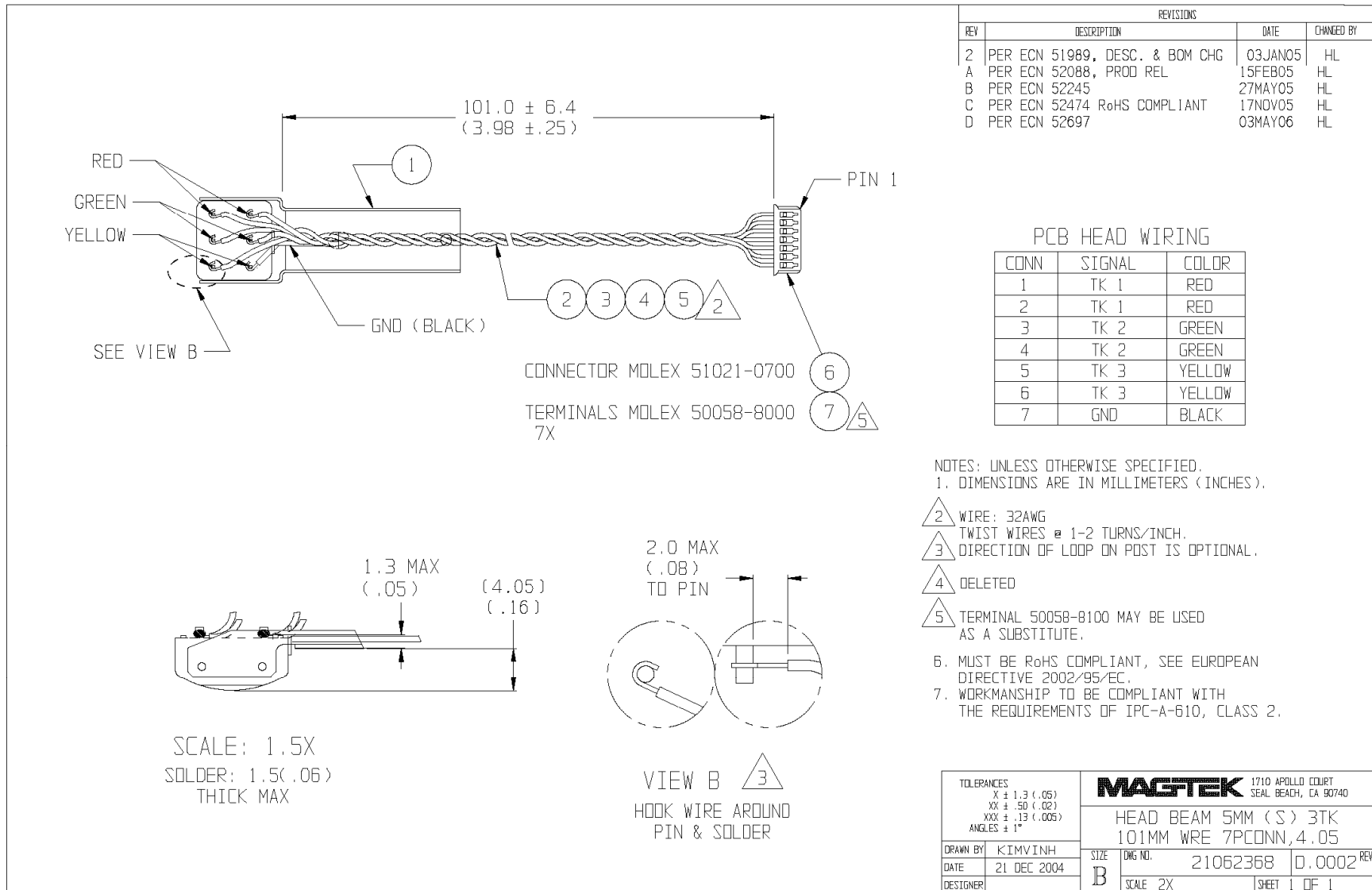

Figure A-14. 3-Track Read Head on Beam Assembly with Cable and 7-Pin Connector

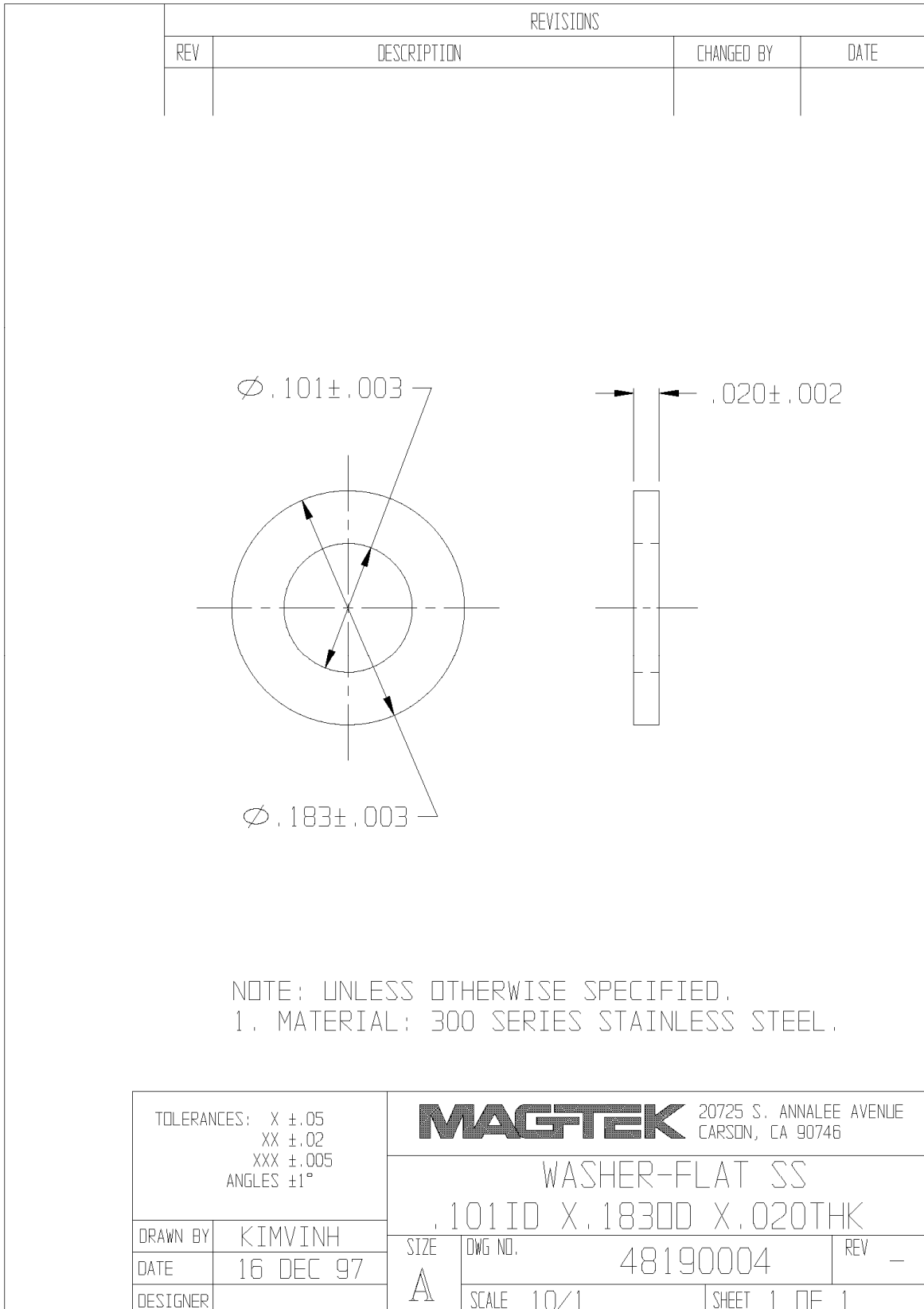

Figure A-15. Washer-Flat SS 0.101 ID x 0.183 OD x 0.020 Thick

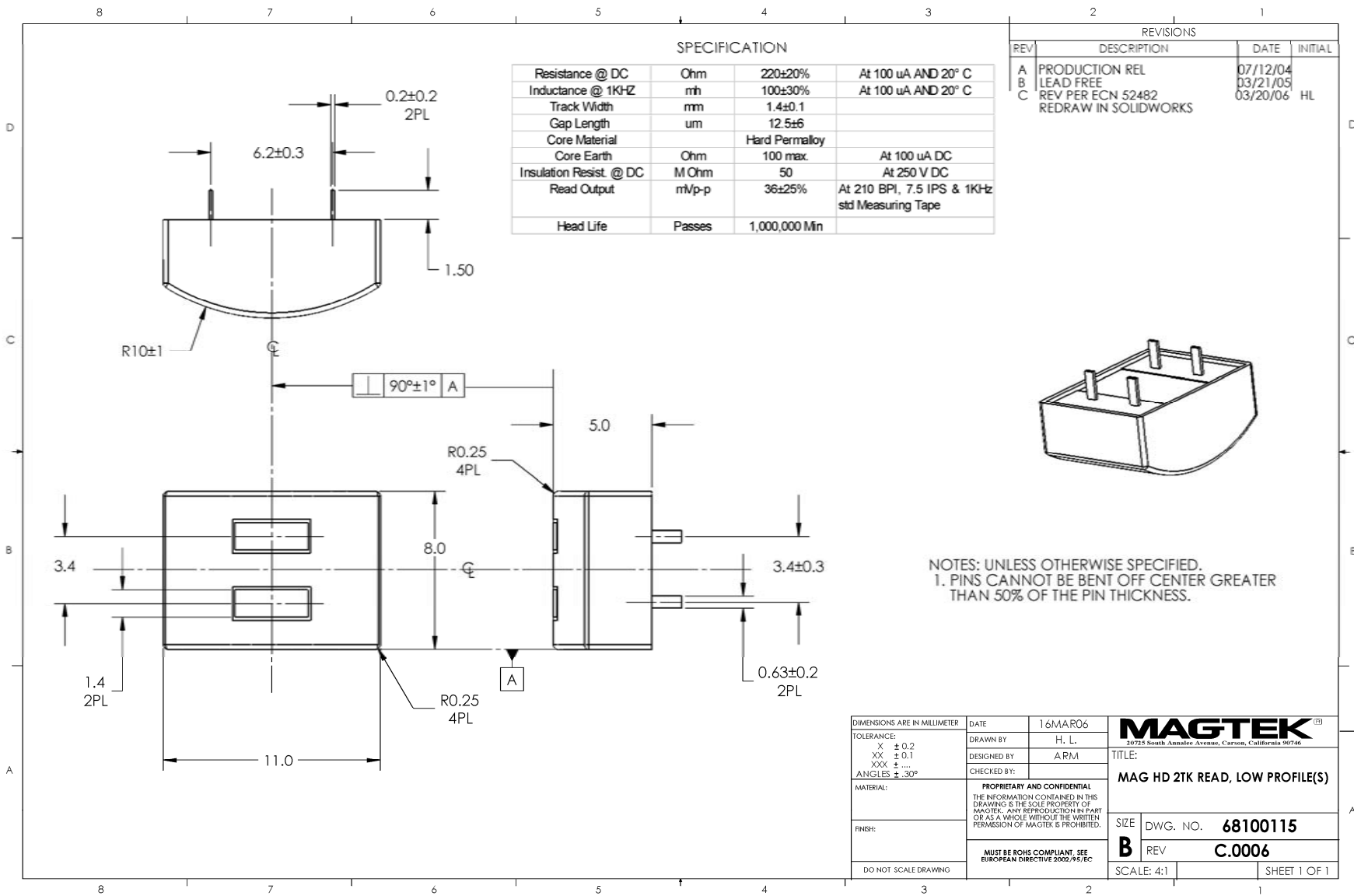

Figure A-16. Magnetic Head, 2-Track Read, Ultra Low Profile

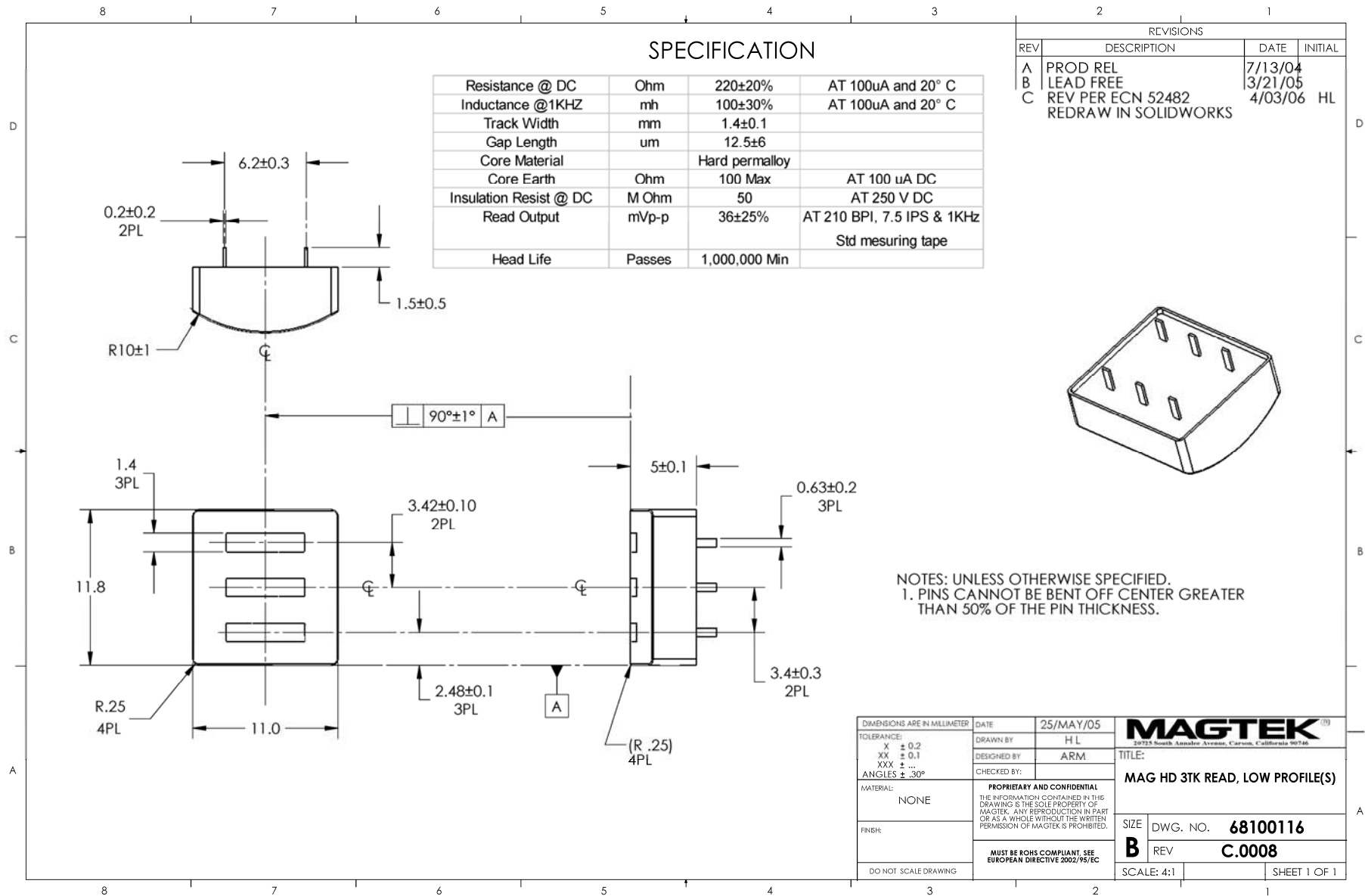

Figure A-17. Magnetic Head, 3-Track Read, Ultra Low Profile

Application Note - Character Conversion

Track 1 Character Set

Character	Card Data							ASCII			
	P	B ₅	B ₄	B ₃	B ₂	B ₁	P0	P1	EP	OP	
Space	1	0	0	0	0	0	20	A0	A0	20	
! (ND)	0	0	0	0	0	0	1	21	A1	21	A1
" (ND)	0	0	0	0	0	1	0	22	A2	22	A2
# (OG)	1	0	0	0	0	1	1	23	A3	A3	23
\$	0	0	0	0	1	0	0	24	A4	24	A4
% (SS)	1	0	0	0	1	0	1	25	A5	A5	25
& (ND)	1	0	0	0	1	1	0	26	A6	A6	26
' (ND)	0	0	0	0	1	1	1	27	A7	27	A7
(0	0	0	1	0	0	0	28	A8	28	A8
)	1	0	0	1	0	0	1	29	A9	A9	29
* (ND)	1	0	0	1	0	1	0	2A	AA	AA	2A
+ (ND)	0	0	0	1	0	1	1	2B	AB	2B	AB
, (ND)	1	0	0	1	1	0	0	2C	AC	AC	2C
-	0	0	0	1	1	0	1	2D	AD	2D	AD
.	0	0	0	1	1	1	0	2E	AE	2E	AE
/	1	0	0	1	1	1	1	2F	AF	2F	AF
0	0	0	1	0	0	0	0	30	B0	30	B0
1	1	0	1	0	0	0	1	31	B1	B1	31
2	1	0	1	0	0	1	0	32	B2	B2	32
3	0	0	1	0	0	1	1	33	B3	33	B3
4	1	0	1	0	1	0	0	34	B4	B4	34
5	0	0	1	0	1	0	1	35	B5	35	B5
6	0	0	1	0	1	1	0	36	B6	36	B6
7	1	0	1	0	1	1	1	37	B7	B7	37
8	1	0	1	1	0	0	0	38	B8	B8	38
9	0	0	1	1	0	0	1	39	B9	39	B9
: (ND)	0	0	1	1	0	1	0	3A	BA	3A	BA
; (ND)	1	0	1	1	0	1	1	3B	BB	BB	3B
< (ND)	0	0	1	1	1	0	0	3C	BC	3C	BC
= (ND)	1	0	1	1	1	0	1	3D	BD	BD	3D
> (ND)	1	0	1	1	1	1	0	3E	BE	BE	3E
? (ES)	0	0	1	1	1	1	1	3F	BF	3F	BF

Character	Card Data							ASCII			
	P	B ₅	B ₄	B ₃	B ₂	B ₁	P0	P1	EP	OP	
@ (ND)	0	1	0	0	0	0	0	40	C0	C0	40
A	1	1	0	0	0	0	1	41	C1	41	C1
B	1	1	0	0	0	1	0	42	C2	42	C2
C	0	1	0	0	0	1	1	43	C3	C3	43
D	1	1	0	0	1	0	0	44	C4	44	C4
E	0	1	0	0	1	0	1	45	C5	C5	45
F	0	1	0	0	1	1	0	46	C6	C6	46
G	1	1	0	0	1	1	1	47	C7	47	C7
H	1	1	0	1	0	0	0	48	C8	48	C8
I	0	1	0	1	0	0	1	49	C9	C9	49
J	0	1	0	1	0	1	0	4A	CA	CA	4A
K	1	1	0	1	0	1	1	4B	CB	4B	CB
L	0	1	0	1	1	0	0	4C	CC	CC	4C
M	1	1	0	1	1	0	1	4D	CD	4D	CD
N	1	1	0	1	1	1	0	4E	CE	4E	CE
O	0	1	0	1	1	1	1	4F	CF	CF	4F
P	1	1	1	0	0	0	0	50	D0	50	D0
Q	0	1	1	0	0	0	1	51	D1	D1	51
R	0	1	1	0	0	1	0	52	D2	D2	52
S	1	1	1	0	0	1	1	53	D3	53	D3
T	0	1	1	0	1	0	0	54	D4	D4	54
U	1	1	1	0	1	0	1	55	D5	55	D5
V	1	1	1	0	1	1	0	56	D6	56	D6
W	0	1	1	0	1	1	1	57	D7	D7	57
X	0	1	1	1	0	0	0	58	D8	D8	58
Y	1	1	1	1	0	0	1	59	D9	59	D9
Z	1	1	1	1	0	1	0	5A	DA	5A	DA
[(ND)	0	1	1	1	0	1	1	5B	DB	DB	5B
\ (ND)	1	1	1	1	1	0	0	5C	DC	5C	DC
] (ND)	0	1	1	1	1	0	1	5D	DD	DD	5D
^ (FS)	0	1	1	1	1	1	0	5E	DE	DE	5E
_ (ND)	1	1	1	1	1	1	1	5F	DF	5F	DF

Track 2 and 3 Character Set

Character	Card Data					ASCII			
	P	B ₄	B ₃	B ₂	B ₁	P0	P1	EP	OP
0	1	0	0	0	0	30	B0	30	B0
1	0	0	0	0	1	31	B1	B1	31
2	0	0	0	1	0	32	B2	B2	32
3	1	0	0	1	1	33	B3	33	B3
4	0	0	1	0	0	34	B4	B4	34
5	1	0	1	0	1	35	B5	35	B5
6	1	0	1	1	0	36	B6	36	B6
7	0	0	1	1	1	37	B7	B7	37

Character	Card Data					ASCII				Hex Character
	P	B ₄	B ₃	B ₂	B ₁	P0	P1	EP	OP	
8	0	1	0	0	0	38	B8	B8	38	
9	1	1	0	0	1	39	B9	39	B9	
: (AS)	1	1	0	1	0	3A	BA	3A	BA	A
; (SS)	0	1	0	1	1	3B	BB	BB	3B	B
< (ND)	1	1	1	0	0	3C	BC	3C	BC	C
= (FS)	0	1	1	0	1	3D	BD	BD	3D	D
> (ND)	0	1	1	1	0	3E	BE	BE	3E	E
? (ES)	1	1	1	1	1	3F	BF	3F	BF	F

P = Parity
 EP = Even Parity
 OP = Odd Parity
 P0 = Parity bit set to 0
 P1 = Parity bit set to 1
 SS = Start Sentinel
 ES = End Sentinel
 FS = Field Separator

AS = Account Separator (Track 3 only)
 ND = Character Not Defined by Credit Card Standards
 OG = Optional Graphic

MAGTEK®

REGISTERED TO ISO 9001:2000

1710 Apollo Court, Seal Beach, CA 90740
 Phone: (562) 546-6400, Help Line (651) 415-6800
 Fax (562) 546-6301 <http://www.magtek.com>
 P/N 99875065-4, 4/03 Copyright © 2000-2003, Mag-Tek®, Inc.

Figure A-18. ASCII Character Conversion Chart